

NOTE: This is an installation *supplement*. Please refer to the original IOM for all applicable products before using this document.



**APPLICATION:**

The following installation instructions supplement is intended for CVS models FD or FDD 1½ hour rated Fire Dampers and model FSD 1½ hour rated Combination Fire/Smoke Dampers. This installation supplement will show how to install these dampers in a 1 & 2 hour fire rated cavity shaft wall partition with Metal Stud Framing.

**INSTALLATION NOTES:**

1. Gypsum panels must be screwed 12" (305mm) O.C. maximum to all stud and runner flanges surrounding opening. (See Figure 1 and Figure 2 for Opening Preparation Details).
2. Fire damper and sleeve assemblies 80"x50" (2032x1270), 50"x80" (1270x2032), or 40"x84" (1016x2134) and smaller only require retaining angles on one side of the partition (see Figures 3 and 4 on next page). Retaining angles must be attached to the sleeve and the partition. Larger damper assemblies require retaining angles on both sides of the partition.

3. Retaining angles must be a minimum of 16 gauge steel and have a minimum of 1½"x1½" (38x38) legs. For metal stud partitions only, the single-side mounting angle may be directly attached to the metal stud or over the gypsum.
4. Retaining angles must be attached to the partition and sleeve using one of the methods shown below:
  - Tack welds, 1/2" (13mm) long
  - #10 sheet metal screws or bolts
  - Screw length - the screw must engage the stud/track by a minimum of 1/2" (13mm).
5. Wall fasteners - A minimum of two connections per side, top and bottom, 12" (305mm) on center maximum for openings 48"x36" (1219x914) and less, and 6" (152mm) on center for openings 80"x50" (2032x1270), 50"x80" (1270x2032) and 40"x84" (1016x2134) or less.
6. Sleeve fasteners - 6" (152mm) max on center.
7. Retaining angles must overlap the partition a minimum of 1" (25mm).

These installation instructions apply to the following wall design numbers as detailed in the UL Fire Resistance Directory: U438, U469, U497.

**FIGURE 1: OPENING PREPARATION DETAIL**

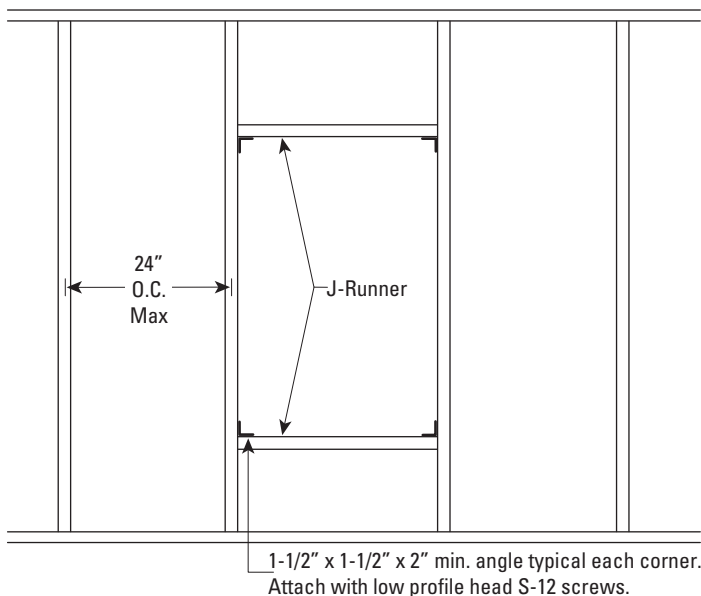

**FIGURE 2: OPTIONAL OPENING PREPARATION DETAIL FOR I-STUD ASSEMBLY**

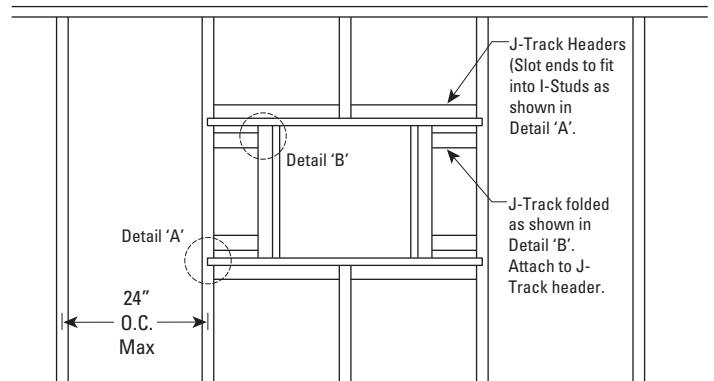

**DETAIL 'A': J-TRACK TO I-STUD CONNECTION**

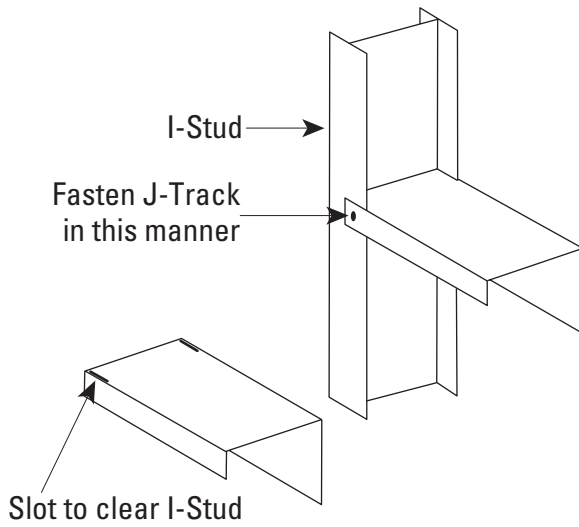

**DETAIL 'B': FORMING J-TRACK**

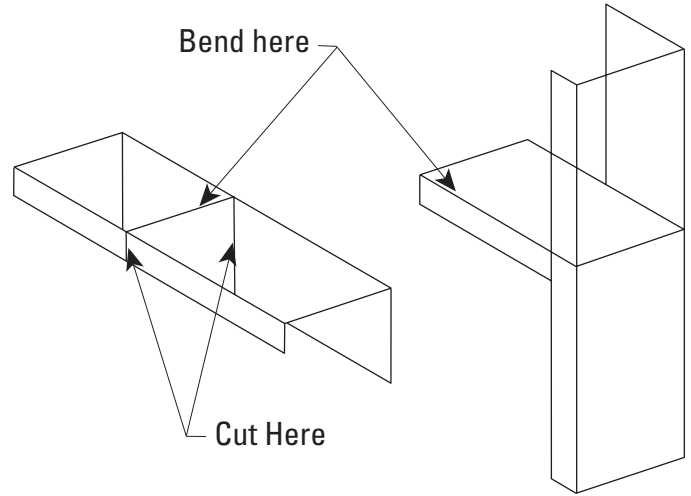

**FIGURE 3: 1 HOUR SHAFTWALL RATING**

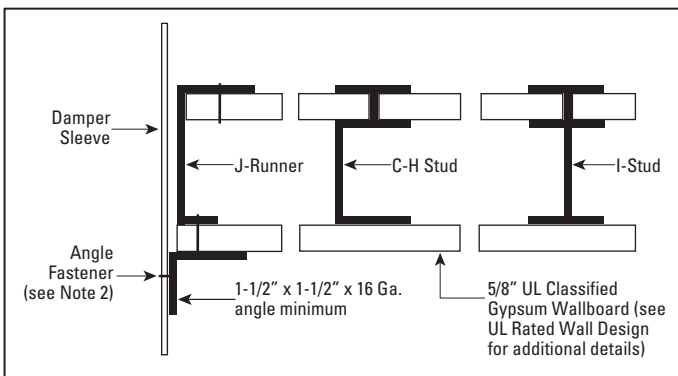

**FIGURE 4: 2 HOUR SHAFTWALL RATING**

